

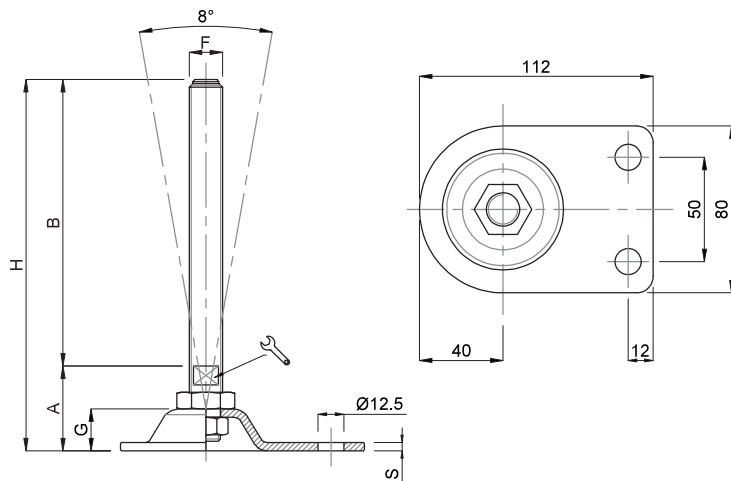

**Caratteristiche: BASE Ø 80X112 CON 2 FORI,
STELO SNODATO 8° O FISSO CON DADO**

**Features: BASE Ø 80X112 WITH 2 BORES, 8° ARTICULATED STEM OR FIX
BY BOTTOM LOCKING NUT**



CODICE - CODE	descrizione description	DIMENSIONI PRINCIPALI - MAIN DIMENSIONS							CARICO STATICO STATIC LOAD NEWTON
		S	B	A		F	G	H	
15730/FIX	M16X150	3	150	39,5	13	M16	19	189,5	20000
15732/FIX	M16X200	3	200	39,5	13	M16	19	239,5	20000
15734/FIX	M20X150	3	150	40,5	17	M20	19	190,5	20000
15736/FIX	M20X200	3	200	40,5	17	M20	19	240,5	20000

Caratteristiche: BASE Ø 110X151 CON 2 FORI, STELO SNODATO 8° O FISSO CON DADO

Features: BASE Ø 110X151 WITH 2 BORES, 8° ARTICULATED STEM OR FIX BY BOTTOM LOCKING NUT

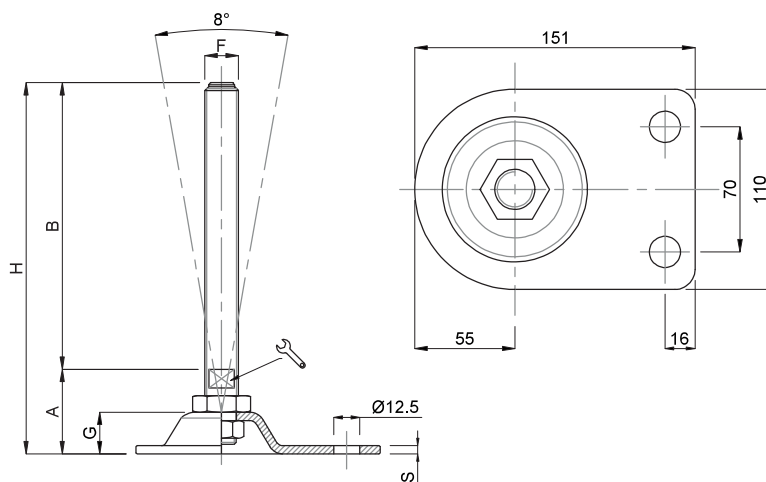

CODICE - CODE	descrizione description	DIMENSIONI PRINCIPALI - MAIN DIMENSIONS							CARICO STATICO STATIC LOAD NEWTON
		S	B	A		F	G	H	
15740/FIX	M16X150	4	150	41	17	M16	19	191	25000
15742/FIX	M16X200	4	200	41	17	M16	19	241	25000
15744/FIX	M20X150	4	150	42	17	M20	19	192	25000
15746/FIX	M20X200	4	200	42	17	M20	19	242	25000
15748/FIX	M24X150	4	150	43	20	M24	19	193	30000
15750/FIX	M24X200	4	200	43	20	M24	19	243	30000

• Base stampata in acciaio inox AISI 304. Stelo acciaio inox AISI 304. Su richiesta l'elemento di livellamento viene fornito con dado in acciaio

• Material: stainless steel base 1.4301. Stainless steel screw 1.4301. The levelling element could be supplied with steel nut.